

EX 221 – S300L

TECHNICAL SPECIFICATIONS

Excavator size	> 15 ton
Drill mast	S300 L Gear Box
Stroke	Standard 3350 mm (other strokes on request)
Pull back / down	2.500 Kg
Base frame and Kinematic	Include plate to attach to your excavator with: <ul style="list-style-type: none"> • Single slew WDL 343 for mast rotation (180°+180°) • Back feed 700mm • Side chain guide for hoses
Hydraulics	5 proportional valves (rotation/ percussion/ feed/ slew / back feed)
Controls	Radio remote control and LCD screen for diagnostic and setting
Centralizer	Manual centralizer included
Data log	On request

MAIN FRAME ACCESSORIES AND OPTIONS

90° cylinder mounted before slew for extra mast inclination
Extra slew WDL 343 DM unit with 90° structure for extra mast inclination
Spider excavator foot main frame
180° actuator for side mast rotation

DRILL MAST ACCESSORIES AND OPTIONS

Clamp and break device	50-156; 54-180K; 50-190
Slidramatic	Rotary head lateral movement
Winch	800 kg winch with pulley
Water pump	25 lt at 40 bars
Lubricator	1 lt – 6 lt – 9 lt

SAFETY GARD OPTIONS

Manual	Manual opening type
Electronic	Electronic front guard and lateral steel guard
Hydraulic	Corner opening hydraulic type

ROTARY HEADS AND DRIFTERS

Rotary heads	RP500 - RP 800 - RH6
Drifters	<ul style="list-style-type: none"> • EURODRILL RH4 X - RH6 X • Floating spindle kit for DTH available

SLEW + 90° CYLINDER VERSION

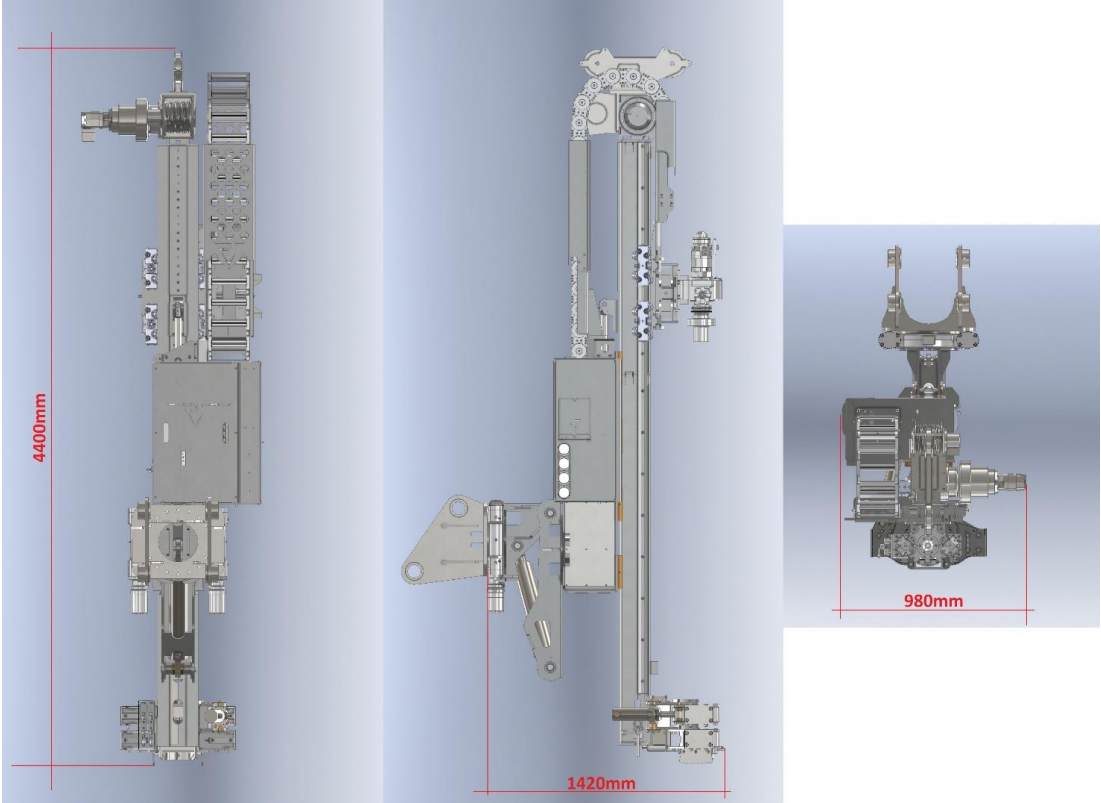

DOUBLE SLEW VERSION

