

EAGLE 800 B

PESO (senza accessori)

6000 kg

COMANDI IDRAULICI PROPORZIONALI

Interamente radiocomandati Load Sensing

CARRO CINGOLATO

Passo cingolo 1650 mm

Lunghezza 2500 mm

Larghezza suole 315 mm

Velocità max 2 kmh

CENTRALE IDRAULICA

Motore diesel Kubota V3300 DI-T

Potenza motore a 2600 rpm 64.5 KW - 86 Cv.

Pompa idraulica a portata variabile

180 l./min. p.max 180 bar

Serbatoio olio 180 lt.

Serbatoio gasolio 100 lt.

MAST

Acciaio Alluminio

Corsa utile 2300 mm 3300 mm

Lunghezza

3600 mm 4900 mm

Tiro/spinta 4500 daN 1500 daN

TESTA

Testa di rotazione Martello idraulico

Modello RP800 HD2004

Coppia max 850 kgm 440 kgm

Giri max 40 rpm 144 rpm

Filetto albero 31/2" API REG R32 R38 T38 T45

T51 API 2 3/8" API 3 1/2"

ACCESSORI

MORSE DOPPIE

Diam. min. morse Diam. max morse

Tipo 1 30 mm. 150 mm.

Tipo 2 50 mm. 190 mm.

Tiro argano 800 daN

Lubrificatore ASL290 (6lt. a 24 bar)

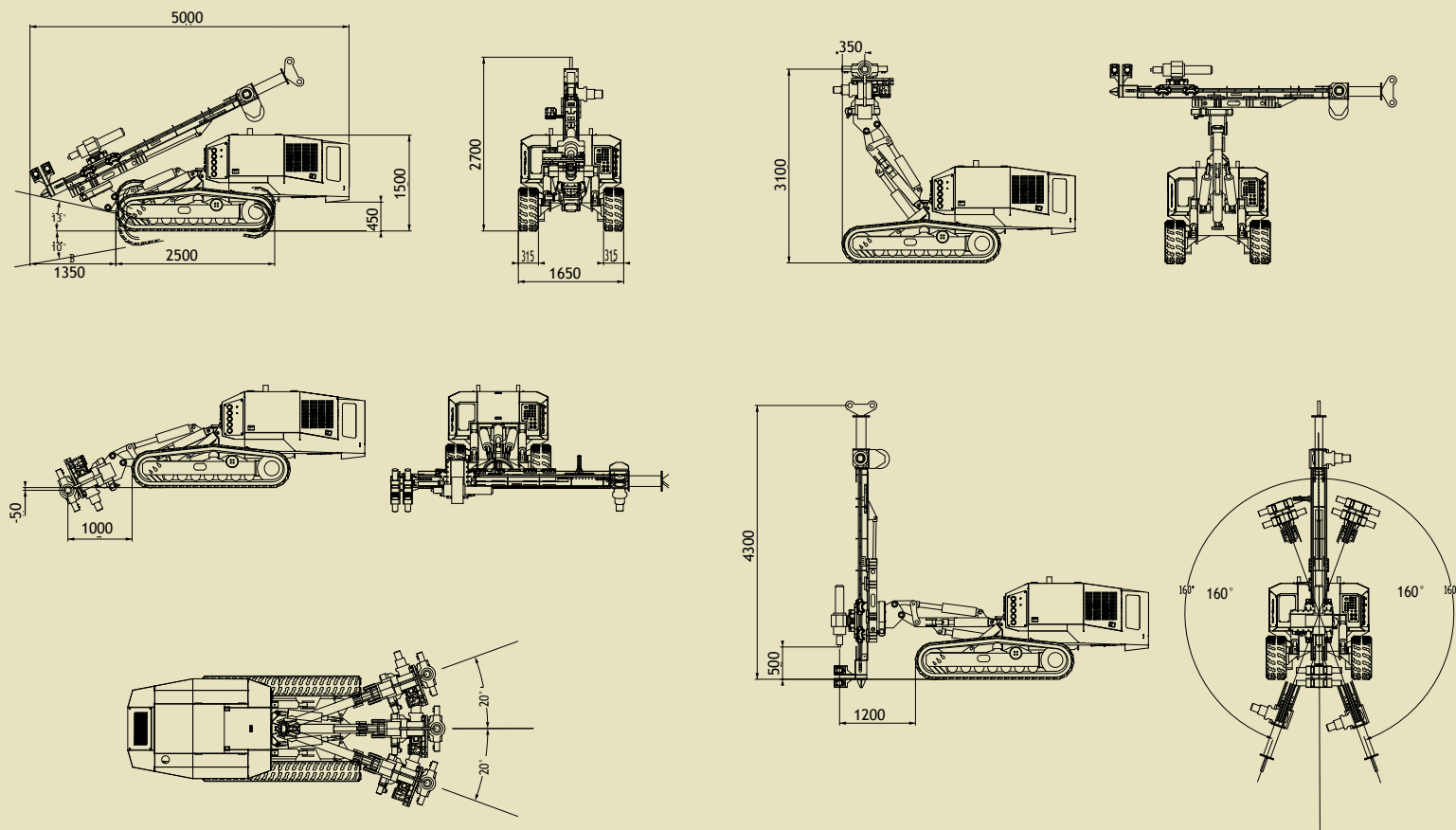

Riparamenti



PERFORATRICE IDRAULICA CON CINGOLO BASCULANTE PREDISPOSTA PER MARTELLI A ROTOPERCUSSIONE E/O PER MARTELLI FONDOFORO, COMPLETAMENTE RADIO-COMANDATA

COMPACT HYDRAULIC DRILL RIG WITH OSCILLATING TRACKS, SUITABLE FOR TOP HAMMERS AND/OR DOWN-THE HOLE HAMMERS, COMPLETELY RADIO REMOTE CONTROLLED

PERFORATRICE IDRAULICA CINGOLATA
COMPACT HYDRAULIC DRILL RIG

EAGLE 800 B



PERFORAZIONE
DRILLING



DEMOLIZIONE
DEMOLITION